



Ocean Sensor Systems, Inc.

RF Wave Logger III, OSSI-010-011

A Self Logging/Self Powered Wave Staff
With RF Data Transmission & Self Grounding Coaxial Staff

General Description

The OSSI010-011 RF Wave Logger III combines a high performance Wave Staff Circuit, a Compact Flash Card Data Logger, an RF Data Transmission System, a Rugged Waterproof Package and 4 C Size Alkaline Batteries. An optional Solar Powered Configuration is also available for years of totally independent autonomous operation. The wireless transmitted data can also be stored in the unit on a Compact Flash Card. The transmitted data is received by the included RF Modem which can connect to any PC's serial port. The Flash Card can also be removed and read on any PC with a Flash Card Reader. The RF Wave Logger will operate for months in Buffered Transmit Mode on the 4 C Size Batteries. The unit's circuits are temperature stable providing repeatable measurements to better than 0.1%. The RF Wave Logger is easily programmed via a PC serial port using our Free RF Wave Logger Interface Software or a Hyper Terminal program.

Features

- **Wireless Data Connection**
- **MaxStream 900MHz 140mW Modem**
- **Compact Flash Card Storage up to 2GB**
- **4 C Size Alkaline Batteries**
- **Months of Continuous Operation**
- **Years of Burst Operation**
- **Optional 5W Solar Module**
- **Rugged Sealed Waterproof Design**
- **Interchangeable Teflon Coated Staff**
- **Fully Programmable via RS232**
- **PC Interface Software**
- **Binary or ASCII Data Format**
- **Sample Rate Up to 30Hz**
- **Accuracy $\pm 0.25\%$, 20-80% of Full Scale**
- **Linearity 0.25%, 20-80% of Full Scale**
- **Resolution 0.025%**
- **Accuracy $\pm 1.0\%$, 0-100% of Full Scale**
- **Optional Air Temperature Logging**

Wire Configuration and Dimensions

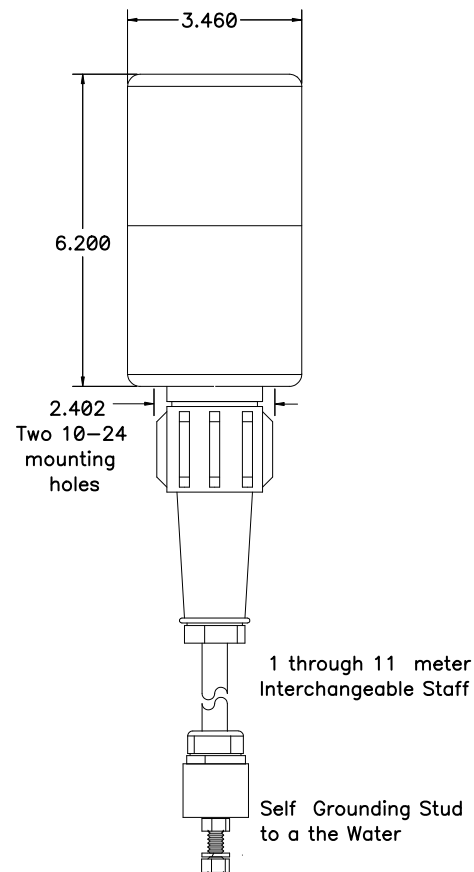

Part Number Selection

		<p>RF Wave Logger: OSSI-010-011A The RF Wave Logger III with Internal Antenna is a self logging, self powered Wave Staff with RF Data Transmission. It combines the high performance Wave Staff Circuit, a Compact Flash Card Data Logger, an RF Data Transmission System, a Rugged Waterproof Package and 4 C Size Alkaline Batteries. It has an outdoor range of 400ft.</p>		
		Staff Length	Staff Type	Antenna
1/2 Meter Cable Staff III	Teflon Coaxial Cable	Internal	4 C Alkaline Batteries	OSSI-010-011A-0.5C
1 Meter Cable Staff III	Teflon Coaxial Cable	Internal	4 C Alkaline Batteries	OSSI-010-011A-1C
1.5 Meter Cable Staff III	Teflon Coaxial Cable	Internal	4 C Alkaline Batteries	OSSI-010-011A-1.5C
2 Meter Cable Staff III	Teflon Coaxial Cable	Internal	4 C Alkaline Batteries	OSSI-010-011A-2C
3 Meter Cable Staff III	Teflon Coaxial Cable	Internal	4 C Alkaline Batteries	OSSI-010-011A-3C
4 Meter Cable Staff III	Teflon Coaxial Cable	Internal	4 C Alkaline Batteries	OSSI-010-011A-4C
5 Meter Cable Staff III	Teflon Coaxial Cable	Internal	4 C Alkaline Batteries	OSSI-010-011A-5C
6 Meter Cable Staff III	Teflon Coaxial Cable	Internal	4 C Alkaline Batteries	OSSI-010-011A-6C
7 Meter Cable Staff III	Teflon Coaxial Cable	Internal	4 C Alkaline Batteries	OSSI-010-011A-7C
8 Meter Cable Staff III	Teflon Coaxial Cable	Internal	4 C Alkaline Batteries	OSSI-010-011A-8C
9 Meter Cable Staff III	Teflon Coaxial Cable	Internal	4 C Alkaline Batteries	OSSI-010-011A-9C
10 Meter Cable Staff III	Teflon Coaxial Cable	Internal	4 C Alkaline Batteries	OSSI-010-011A-10C
11 Meter Cable Staff III	Teflon Coaxial Cable	Internal	4 C Alkaline Batteries	OSSI-010-011A-11C

Electrical Characteristics

Parameter	Conditions	Min.	Typ.	Max.	Units
Battery Voltage		3.6		10	V
Battery Drain	Sleep mode		3		mW
Battery Drain	Continuous 20Hz Sample		6.8		mW
Battery Drain	Transmit Data		760		mW
Data Accuracy	20-80% of Full Scale			0.25	±%
Data Accuracy	0-100% of Full Scale			1.0	±%
Data Resolution	Percent of Full Scale			0.025	%
Data Linearity	Percent of Full Scale			0.25	%

Data and Timing Characteristics

Parameter	Conditions	Min.	Typ.	Max.	Units
Sample Frequency (Note 1)	Programmable	2		30	Hz
Serial Baud Rate			9.6		Kbaud
RF Baud Rate			9.6		Kbaud
Water Level Data	1 thru. 11 Meter Staffs, 0% to 100% Full Scale	0000		4095	counts
Temperature Resolution	Per count from 0°C		0.0625		°C
Temperature Accuracy	-10°C to 65°C -40°C to 65°C			1.25 2.15	± °C
Flash Card Size	FAT16 format	64		2000	Mbytes
Sample Capacity 2000 Mbyte Flash Card	Binary data ASCII data			936 388	Msamples
Sample Burst Time	Programmable	1		60	minutes
Sample Burst Interval	Programmable	1		60	minutes
New File Interval	Programmable	1		255	days
RF Buffered Data Size			363		Samples
Real Time Clock Accuracy				20	ppm

Note 1: 20Hz maximum when Compact Flash Card is installed.

Mechanical Characteristics

Parameter	Conditions	Min.	Typ.	Max.	Units
Environment	Waterproof		30		meters
Cable Tension		0	50	500	Newtons

Two Modes of wireless Transmission:

The Buffered Mode transmits the data after each 363 samples. This mode leaves the radio off most of the time which reduces the drain on the batteries. It is recommended for most applications. A header is attached to each set of buffered transmissions with time, date, sample frequency, staff length and temperature. See the following charts and examples for battery life and received data format.

The Continuous Mode transmits the data immediately after each sample. This mode leaves the radio on continuously which will drain the batteries in a short time. It is only recommended for low Burst rates, short durations or testing. See the following charts and examples for battery life and received data format.

Battery Life for buffered Transmit Mode:

Battery life is a function of Sample Frequency, Burst Time and the Burst Interval.

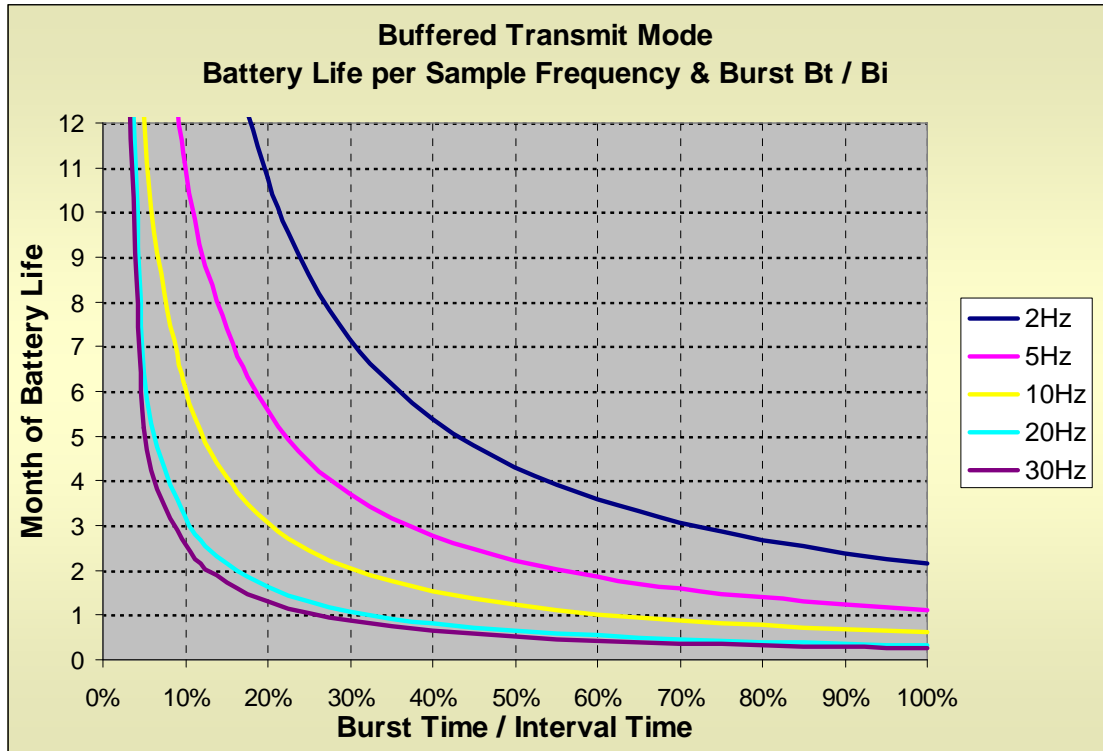

Battery Life For Continuous Transmit Mode:

Battery life is a function of Sample Frequency, Burst Time and the Burst Interval.

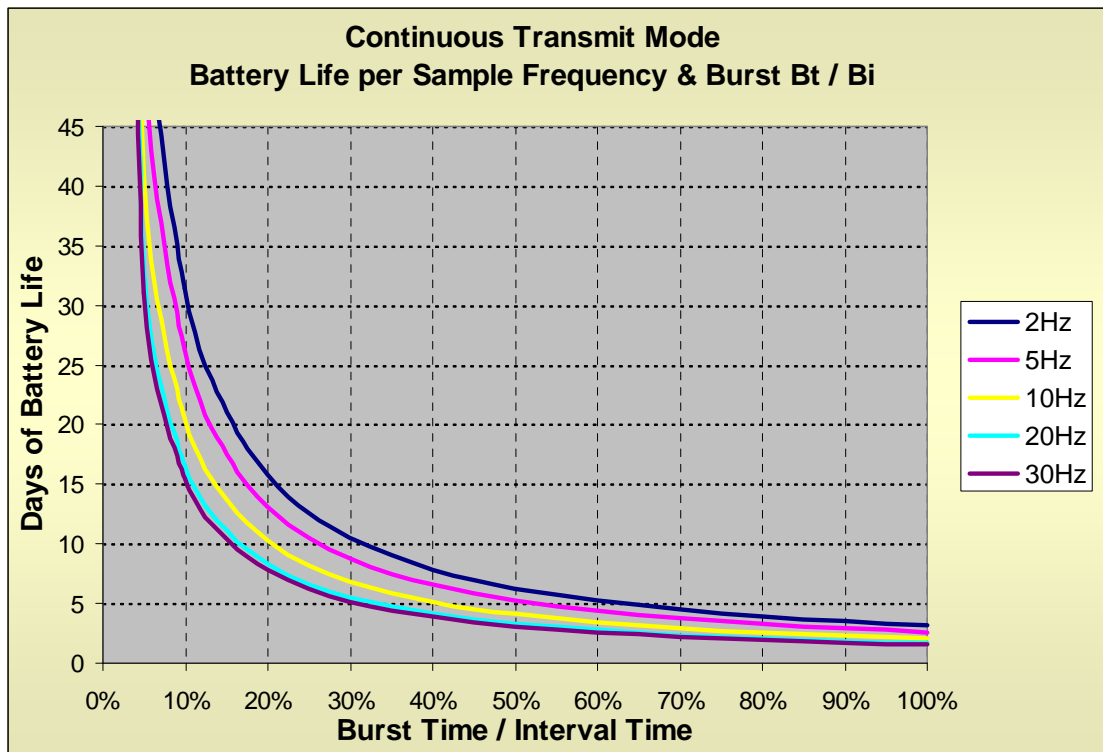

Flash Card Data Storage Time:

Data Storage Time is a function of Sample Frequency, Burst Time, Interval and Data format.

The number of months of Data Storage for a Compact Flash Card may be calculated with the following formula.

$$St = (Sm * CF) / (F * (Bt / Bi) * 2,626,560)$$

Where St = Storage Time in months

Sm = Samples per Mbyte per storage format type

194,000 samples per Mbyte for ASCII

176,000 samples per Mbyte for ASCII format with Air Temperature sampling

468,000 samples per Mbyte for Binary

453,000 samples per Mbyte for Binary format with Air Temperature sampling

CF = Compact Flash card size in Mbytes

F = Programmed Sample Frequency 2Hz, 5Hz, 10Hz, 20Hz, or 30Hz

Bt = Burst Time in minutes

Bi = Burst Interval in minutes

2,626,560 = Seconds per month

512 M byte Compact Flash card:

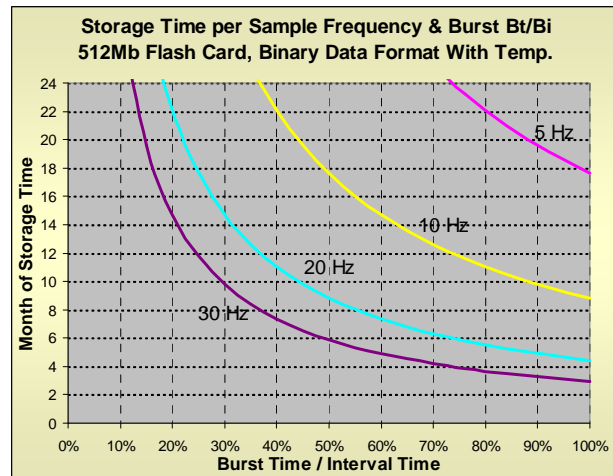
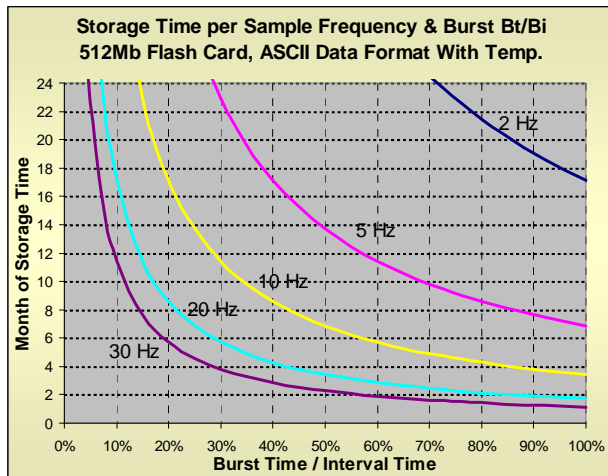

256 M byte Compact Flash card:

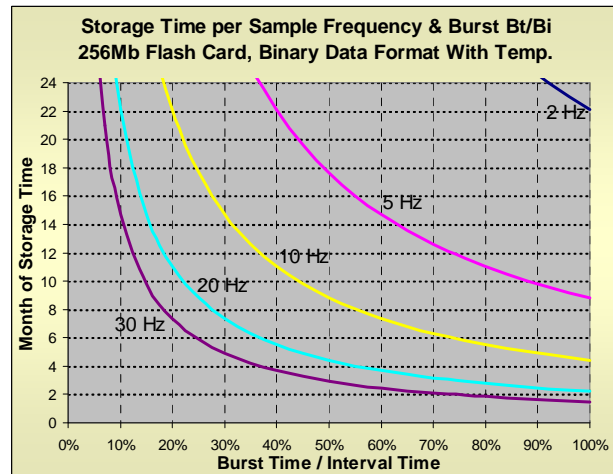
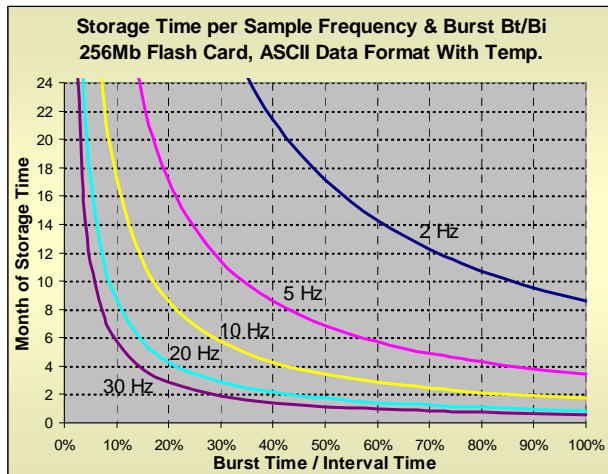

Flash Card Data Storage Time cont:

128 M byte Compact Flash card:

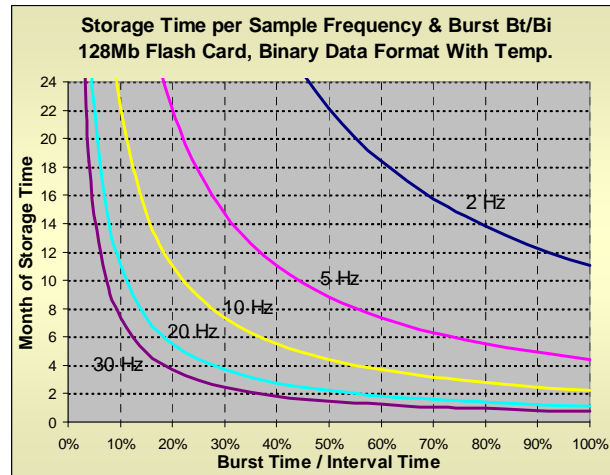
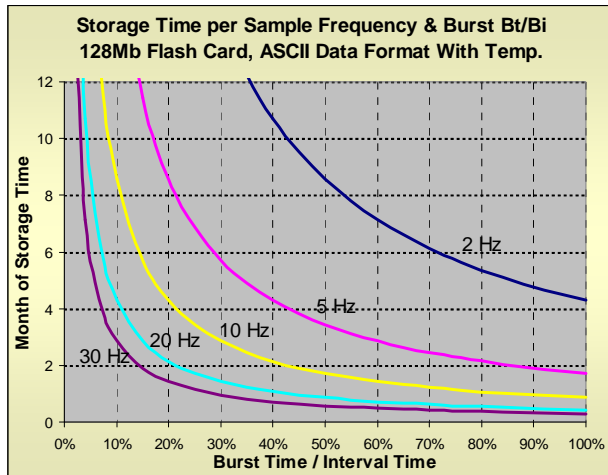

Flash Card Number of Files and File Name:

The maximum number of files that the Wave Logger can create is 512. The file names are automatically created starting at WLOG_000 and sequence up to WLOG_511. If previous files were left on the Compact Flash card those file names will be skipped. Note file name (location) WLOG_000 may be reserved and hidden by the Compact Flash Card manufacture.

Flash Card File Format:

A File Header is placed at the start of each file when created. The Header contains the creation time, date and configuration information. The time and date are also placed at the start of each new burst.

New File Header Layout, Comma Delimited (separated)

Offset	Length & Type	File Status: Time, Date and Configuration Data
00h	4 ASCII bytes	Y00, to Y99, for Year 2000 to 2099
04h	4 ASCII bytes	M01, to M12, for Month Jan to Dec
08h	4 ASCII bytes	D01, to D31, for Day of month 1 to 31
0Ch	4 ASCII bytes	H00, to H23, for Hour of Day midnight to 23:00 hrs
10h	4 ASCII bytes	M00, to M59, for Minute of Hour 00 to 59
14h	4 ASCII bytes	S00, to S59, for Second of Minute 00 to 59
18h	4 ASCII bytes	F02, F05, F10, F20, F30, Sample Frequency in Hz
1Ch	4 ASCII bytes	L01, to L60, Burst Length 1 to 60 Minutes (note 1)
20h	4 ASCII bytes	I01, to I60, Burst Interval 1 to 60 Minutes
24h	5 ASCII bytes	N001, to N255, New File Interval 1 to 255 days (note 1)
28h	3 ASCII bytes	A?, Prescale value, set per Staff Length, see note 2
2Dh	5 ASCII bytes	C???, Cycle count, set for Staff Length, see note 3
30h	4 ASCII bytes	T00, Wave Logger Type 00 = OSSI-010-004 Version 1.0
35h	6 ASCII bytes	R0000, Reserved
3Bh	4 Binary bytes	0Dh 0Ah 0Dh 0Ah Two carriage return line feeds

Note 1: 0 = continuous

Note 2: A? See page 15 Staff Length Configuration Table, Column Staff Length Prescaler Hex Value and convert to decimal number

Note 3: C??? See page 15 Staff Length Configuration Table, Column Staff Length Counter Hex Value and convert to decimal number

New Burst Header Layout, Comma Delimited (separated)

Offset	Length & Type	Burst Status: Start Time and Date
3Fh	4 ASCII bytes	Y00, to Y99, for Year 2000 to 2099
43h	4 ASCII bytes	M01, to M12, for Month Jan to Dec
47h	4 ASCII bytes	D01, to D31, for Day of month 1 to 31
4Bh	4 ASCII bytes	H00, to H23, for Hour of Day midnight to 23:00 hrs
4Fh	4 ASCII bytes	M00, to M59, for Minute of Hour 00 to 59
53h	4 ASCII bytes	S00, to S59, for Second of Minute 00 to 59
57h	2 Binary bytes	0Dh 0Ah One carriage return line feed

Flash Card File Data Format:

The file data may be stored in ASCII or Binary format and with or without Air Temperature. After each set of 12 Wave Data samples stored, an Air Temperature sample is inserted if the temperature option is selected. Then a carriage return line feed is added if in ASCII format. In binary format two hex FE bytes will be added. At the end of each burst two carriage return line feeds are added in ASCII format or two hex FF bytes in binary format.

Sampled Data in ASCII Format, Comma Delimited with Air Temperature

Offset	Length & Type	Data Description
59h	5 ASCII bytes	0000, to 4095, Water Level Sample #1 0 to Full Scale
5E	5 ASCII bytes	0000, to 4095, Water Level Sample #2 0 to Full Scale
63h	5 ASCII bytes	0000, to 4095, Water Level Sample #3 0 to Full Scale
68h	5 ASCII bytes	0000, to 4095, Water Level Sample #4 0 to Full Scale
6Dh	5 ASCII bytes	0000, to 4095, Water Level Sample #5 0 to Full Scale
72h	5 ASCII bytes	0000, to 4095, Water Level Sample #6 0 to Full Scale
77h	5 ASCII bytes	0000, to 4095, Water Level Sample #7 0 to Full Scale
7Ch	5 ASCII bytes	0000, to 4095, Water Level Sample #8 0 to Full Scale
81h	5 ASCII bytes	0000, to 4095, Water Level Sample #9 0 to Full Scale
86h	5 ASCII bytes	0000, to 4095, Water Level Sample #10 0 to Full Scale
8Bh	5 ASCII bytes	0000, to 4095, Water Level Sample #11 0 to Full Scale
90h	5 ASCII bytes	0000, to 4095, Water Level Sample #12 0 to Full Scale
95h	6 ASCII bytes	-0640, To +1024, Air Temp. -40 to +65 C, 0.0625 C per count
9Bh	2 Binary bytes	0Dh 0Ah One carriage return line feed
9Dh	5 ASCII bytes	0000, to 4095, Water Level Sample #13 0 to Full Scale
??h	5 ASCII bytes	0000, to 4095, Water Level Sample #?? 0 to Full Scale
??h	4 Binary bytes	0Dh 0Ah 0Dh 0Ah Two carriage return line feeds

Flash Card File Data Format cont:

Sampled Data in ASCII Format, Comma Delimited without Air Temperature

Offset	Length & Type	Data Description
59h	5 ASCII bytes	0000, to 4095, Water Level Sample #1 0 to Full Scale
5E	5 ASCII bytes	0000, to 4095, Water Level Sample #2 0 to Full Scale
63h	5 ASCII bytes	0000, to 4095, Water Level Sample #3 0 to Full Scale
68h	5 ASCII bytes	0000, to 4095, Water Level Sample #4 0 to Full Scale
6Dh	5 ASCII bytes	0000, to 4095, Water Level Sample #5 0 to Full Scale
72h	5 ASCII bytes	0000, to 4095, Water Level Sample #6 0 to Full Scale
77h	5 ASCII bytes	0000, to 4095, Water Level Sample #7 0 to Full Scale
7Ch	5 ASCII bytes	0000, to 4095, Water Level Sample #8 0 to Full Scale
81h	5 ASCII bytes	0000, to 4095, Water Level Sample #9 0 to Full Scale
86h	5 ASCII bytes	0000, to 4095, Water Level Sample #10 0 to Full Scale
8Bh	5 ASCII bytes	0000, to 4095, Water Level Sample #11 0 to Full Scale
90h	5 ASCII bytes	0000, to 4095, Water Level Sample #12 0 to Full Scale
95h	2 Binary bytes	0Dh 0Ah One carriage return line feed
97h	5 ASCII bytes	0000, to 4095, Water Level Sample #13 0 to Full Scale
??h	5 ASCII bytes	0000, to 4095, Water Level Sample #?? 0 to Full Scale
??h	4 Binary bytes	0Dh 0Ah 0Dh 0Ah Two carriage return line feeds

Sampled Data in Binary Format with Air Temperature:

Offset	Length & Type	Data Description
59h	2 Binary bytes	00 00h, to 0F FFh, Water Level Sample #1 0 to Full Scale
5Bh	2 Binary bytes	00 00h, to 0F FFh, Water Level Sample #2 0 to Full Scale
5Dh	2 Binary bytes	00 00h, to 0F FFh, Water Level Sample #3 0 to Full Scale
5Eh	2 Binary bytes	00 00h, to 0F FFh, Water Level Sample #4 0 to Full Scale
61h	2 Binary bytes	00 00h, to 0F FFh, Water Level Sample #5 0 to Full Scale
63h	2 Binary bytes	00 00h, to 0F FFh, Water Level Sample #6 0 to Full Scale
65h	2 Binary bytes	00 00h, to 0F FFh, Water Level Sample #7 0 to Full Scale
67h	2 Binary bytes	00 00h, to 0F FFh, Water Level Sample #8 0 to Full Scale
69h	2 Binary bytes	00 00h, to 0F FFh, Water Level Sample #9 0 to Full Scale
6Bh	2 Binary bytes	00 00h, to 0F FFh, Water Level Sample #10 0 to Full Scale
6Dh	2 Binary bytes	00 00h, to 0F FFh, Water Level Sample #11 0 to Full Scale
6Fh	2 Binary bytes	00 00h, to 0F FFh, Water Level Sample #12 0 to Full Scale
71h	2 Binary bytes	82 80h to 04 00h, Air Temp. -40 to +65 C, 0.0625 C per count
73h	2 Binary bytes	0Dh 0Ah One carriage return line feed
75h	2 Binary bytes	FE FEh every 12 samples
??h	2 Binary bytes	00 00h, to 0F FFh, Water Level Sample #?? 0 to Full Scale
??h	2 Binary bytes	FF FFh at end of each Burst

Flash Card File Data Format cont:

Sampled Data in Binary Format without Air Temperature:

Offset	Length / Type	Data Description
59h	2 Binary bytes	00 00h, to 0F FFh, Water Level Sample #1 0 to Full Scale
5Bh	2 Binary bytes	00 00h, to 0F FFh, Water Level Sample #2 0 to Full Scale
5Dh	2 Binary bytes	00 00h, to 0F FFh, Water Level Sample #3 0 to Full Scale
5Eh	2 Binary bytes	00 00h, to 0F FFh, Water Level Sample #4 0 to Full Scale
61h	2 Binary bytes	00 00h, to 0F FFh, Water Level Sample #5 0 to Full Scale
63h	2 Binary bytes	00 00h, to 0F FFh, Water Level Sample #6 0 to Full Scale
65h	2 Binary bytes	00 00h, to 0F FFh, Water Level Sample #7 0 to Full Scale
67h	2 Binary bytes	00 00h, to 0F FFh, Water Level Sample #8 0 to Full Scale
69h	2 Binary bytes	00 00h, to 0F FFh, Water Level Sample #9 0 to Full Scale
6Bh	2 Binary bytes	00 00h, to 0F FFh, Water Level Sample #10 0 to Full Scale
6Dh	2 Binary bytes	00 00h, to 0F FFh, Water Level Sample #11 0 to Full Scale
6Fh	2 Binary bytes	00 00h, to 0F FFh, Water Level Sample #12 0 to Full Scale
71h	2 Binary bytes	0Dh 0Ah One carriage return line feed
73h	2 Binary bytes	FE FEh every 12 samples
??h	2 Binary bytes	00 00h, to 0F FFh, Water Level Sample #?? 0 to Full Scale
??h	2 Binary bytes	FF FFh at end of each Burst
??h	2 Binary bytes	FF FFh at end of each Burst

Example - Sampled Data in ASCII Format Comma Delimited with Air Temperature Viewed in notepad:

Y02,M11,D09,H21,M48,S10,F30,L02,I01,N001,A1,C073,T00,R0000,

Y02,M11,D09,H21,M49,S00,
 2177,2177,2178,2177,2177,2177,2177,2177,2177,2177,2177,2177,+0388,
 2177,2177,2177,2177,2177,2177,2177,2177,2178,2177,2177,2178,+0388,
 2177,2177,2177,2177,2177,2178,2177,2177,2178,2177,2177,2177,+0388,
 2177,2177,2177,2177,2177,2177,2177,2177,2177,2177,2177,+0389,
 2177,2177,2177,2177,2177,2178,2177,2177,2177,2177,2177,+0387,
 2177,2177,2177,2177,2177,2177,2177,2177,2177,2177,2177,+0388,
 2177,2177,2177,2177,2177,2177,2177,2178,2177,2177,2178,+0388,
 2177,2177,2177,2177,2177,2177,2177,2177,2177,2177,2177,+0386,
 2177,2177,2177,2177,2177,2177,2177,2177,2177,2177,2177,+0388,
 2177,2178,2177,2177,2177,2177,2177,2177,2177,2177,2177,+0387,
 2177,2177,2177,2177,2177,2177,2177,2177,2177,2177,2177,+0386,
 2177,2177,2177,2177,2177,2177,2177,2177,2177,2177,2177,+0387,
 2177,2177,2177,2177,2177,2177,

Y02,M11,D09,H21,M51,S00,
 2177,2178,2178,2178,2177,2178,2178,2178,2178,2177,2177,+0386,
 2177,2178,2177,2178,2177,2177,2177,2177,2177,2177,2177,2178,+0385,

Flash Card File Format cont:

Example - Sampled Data in ASCII Format Comma Delimited without Air Temperature Viewed in notepad:

Y02,M11,D09,H21,M56,S13,F30,L02,I01,N001,A1,C073,T00,R0000,

Y02,M11,D09,H21,M57,S00,
2593,2593,2593,2593,2593,2593,2593,2593,2593,2593,2593,2593,
2593,2593,2593,2593,2593,2593,2593,2593,2593,2593,2593,2593,
2593,2593,2593,2593,2593,2594,2593,2593,2593,2593,2593,2593,
2593,2593,2593,2593,2593,2593,2593,2593,2593,2594,2593,2593,
2593,2593,2593,2593,2593,2593,2593,2593,2593,2593,2593,2593,
2593,2593,2593,2593,2593,2593,2593,2593,2593,2593,2593,2594,
2593,2593,2593,2593,2593,2593,2593,2593,2593,2593,2593,2593,
2593,2593,2593,2593,2593,2593,2593,2593,2593,2593,2593,2593,
2593,2593,2593,2593,2592,2592,2593,2593,2593,2593,2593,
2593,2594,2593,2593,2593,2593,2593,2593,2593,2593,2593,2593,
2593,2593,2593,2593,2593,2593,2593,2593,2593,2593,2593,2593,
2593,2593,2593,2593,2593,2593,2593,2593,2593,2593,2593,2593,
2593,2593,2593,2593,2593,2593,2593,2593,2593,2593,2593,2593,
2593,2593,2593,2593,2593,2593,2593,2593,2593,2593,2593,2593,
2593,2593,2593,2593,2593,2593,2593,2593,2593,2592,2593,2593,
2593,2593,2593,2593,2593,2592,2593,2592,2593,2593,

Y02,M11,D09,H21,M59,S00,
2593,2592,2593,2593,2593,2592,2593,2593,2593,2593,2592,2593,
2593,2593,2592,2593,2593,2593,2593,2593,2592,2593,2593,2593,

Example - Sampled Data in Binary Format, with Air Temperature:

	0	1	2	3	4	5	6	7	8	9	A	B	C	D	E	F	
00000000	59	30	39	2C	4D	30	38	2C	44	32	32	2C	48	31	31	2C	Y09,M08,D22,H11,
00000010	4D	35	37	2C	53	33	34	2C	46	30	35	2C	4C	30	31	2C	M57,S34,F05,L01,
00000020	49	30	32	2C	4E	30	30	30	2C	41	30	2C	43	31	36	33	I02,N000,A0,C163
00000030	2C	54	30	30	2C	52	30	30	30	2C	0D	0A	FF	FF	59	,	T00,R0000,. .ÿÿY
00000040	30	39	2C	4D	30	38	2C	44	32	32	2C	48	31	31	2C	4D	09,M08,D22,H11,M
00000050	35	38	2C	53	30	30	2C	FE	FE	05	A4	05	A4	05	A4	05	58,S00,þ. . . .
00000060	A4	05	A4	05	A4	05	A4	05	A4	05	A4	05	A4	05	A4	05
00000070	A4	01	96	FE	FE	05	A4	05	A4	05	A4	05	A4	05	A4	05	. -þ.
00000080	A5	05	A5	05	A5	05	A5										

Serial Port Communications and Configuration:

The Wave Logger may be configured with a PC's RS232 serial port. Use our convenient programming software or a Hyper Terminal with the following commands. The serial port settings on your computer are as follows: 9600 baud, 8 data bits, parity none, 1 stop bit, and no flow control.

Commands are two bytes and Acknowledgements are 4 bytes

Commands:

st = Stop running sample routine and wait for command instructions.

w = Write configuration data to Wave Logger from PC.

r = Read back configuration data to PC.

i = Read back ID number to PC.

g = Go run main sample and store data to Compact Flash card routine.

lb = This command puts a unit in Loop Back Mode. See RF Modem Configuration for Wave Loggers with a date code after 8/31/09 below for instructions.

Acknowledgements:

STOK = Acknowledge Stop running command and wait for command instruction.

WOK = Acknowledge Write configuration and wait to receive data from PC.

ROK = Acknowledge Transmit configuration and transmit configuration data to PC.

IOK = Acknowledge ID Command and transmit ID (serial) number to PC.

GOK = Acknowledge go command and go run main sample and store data routine.

BAD = Receive failure or check sum on configuration data error

DOW = Do, write configure Wave Logger. (Wave Logger has not been configured)

DOK = Data Ok, Received configuration string with correct check sum

LBOK = The RF Wave Logger is now in the Loop Back Mode. (Only units with serial number date codes after July 31, 2009)

Monitoring the sampled data:

The sampled data may be monitored via the RS232 serial port if the configuration control byte is set to enable the RS232 port:

Example with Air Temperature enabled:

2345, +0384

: :

2345, +0384

Example without Air Temperature enabled:

2345

:

2345

Staff Length Configuration values for Coax Cable Staff

Staff type	Staff Length Meters	Staff Length Counter Hex Value at offset address 03h	Staff Length Prescaler Hex Value at offset address 06h
Coax Cable Staff	0.25	C7	2
Coax Cable Staff	0.5	C7	1
Coax Cable Staff	1	C7	0
Coax Cable Staff	1.5	85	0
Coax Cable Staff	2	C7	8
Coax Cable Staff	2.5	9F	8
Coax Cable Staff	3	85	8
Coax Cable Staff	3.5	72	8
Coax Cable Staff	4	64	8
Coax Cable Staff	4.5	58	8
Coax Cable Staff	5	50	8
Coax Cable Staff	5.5	48	8
Coax Cable Staff	6	42	8
Coax Cable Staff	6.5	3D	8
Coax Cable Staff	7	39	8
Coax Cable Staff	7.5	35	8
Coax Cable Staff	8	32	8
Coax Cable Staff	8.5	2F	8
Coax Cable Staff	9	2C	8
Coax Cable Staff	9.5	2A	8
Coax Cable Staff	10	28	8
Coax Cable Staff	10.5	26	8
Coax Cable Staff	11	24	8

Control Byte

Bit 7	0
Bit 6	0
Bit 5	1 = Enable Start Sampling Time control 0 = Start Sampling Immediately
Bit 4	1 = Air Temp. enabled 0 = Air Temp disabled
Bit 3	1 = Set Real Time Clock Time and Date per this file 0 = No change to Real Time Clock
Bit 2	0 = 9600 baud, default
Bit 1	1 = RS232 output enabled battery power drain 18 mW in cont. sample mode 0 = RS232 output disabled, battery power drain 5 mW in cont. sample mode Note Transmit data always sent in ASCII format
Bit 0	1 = BIN Data carriage return every 60 digits file stored 0 = ASCII Data File comma delimited and carriage return every 60 char.

Installing and Removing the Compact Flash card:

Install the Compact Flash card with the top label facing down as viewed below. If the power plug is connected the File Status LED will turn on for 3 seconds. If the power plug is not connected the File Status LED will turn on for 3 seconds when it is connected. If the card size or format is incorrect the File Status LED will blink fast for 4 seconds. If the battery voltage is low the LED will not turn on at all.

To remove the card, first press the Close File Button. The File Status LED will indicate that it's ok to unplug the card by a continuous 1 second on and 1 second off blinking. The File Status LED will stop blinking when the card is removed. If the card is removed before pressing the Close File Button **the last file will be corrupted.** The File Status LED will blink fast for 4 seconds to indicate this error

